

3D Detailing of GRC elements

Designing and detailing GRC projects can be a challenging task. However, the functionality of modern 3D detailing software packages can really assist the designer throughout the process. This brief article illustrates, step-by-step, how modern 3D software packages can be used in the task of detailing a simple GRC element.

MATT HANLEY

GRCA

Once the designer has formed a concept of his/her design approach, 3D detailing can greatly improve the process of taking this concept through to the final working drawings.

Using 3D has the advantage of making this process fast, efficient, accurate and easier than traditional 2D drafting techniques.

There are many 3D modelling packages available to the designer and they all have their strengths and weaknesses. However, some of the most desirable features that one should look for are that it is affordable and the graphical user interface (GUI) is user-friendly and simple to learn. Parametric-driven modelling is by far the most efficient and it must support cross-platform transfer of data, i.e., you can export to, and import from, AutoCAD. This is the most important piece of functionality as AutoCAD is by far the most commonly used program for creating and presenting drawn data within the construction industry.

To help illustrate the benefits of 3D detailing we shall take a simple project and move through it in a logical, step-by-step process:

Detailing a simple plinth element

The first stage is always to set out the driving geometry and design parameters (Figure 1). Now we have the basic geometry laid out (Figures 2 and 3), we can work up the shape and detail of the GRC element and consider where we can achieve structural support, restraint and fixity (Figures 4 and 5).

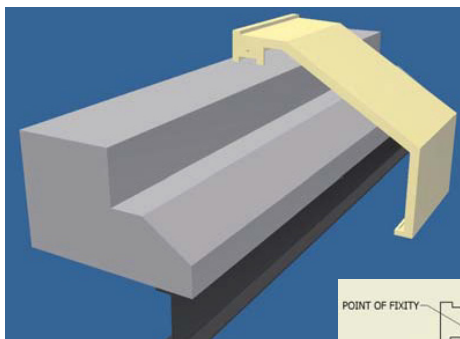
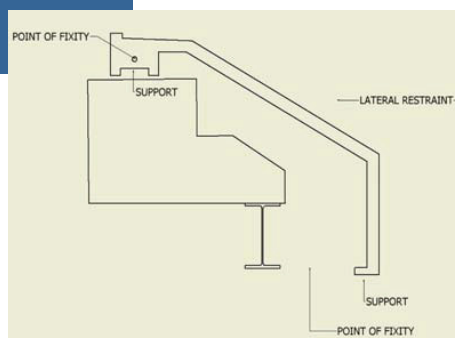

Figure 3: Examine interface options.

Figure 4: Identify points of support/fixing.



This is the fourth techNOTE in a series of technical notes covering aspects of glassfibre reinforced concrete (GRC/GFRC) technology.

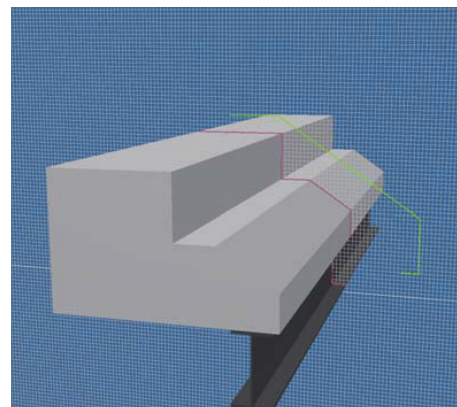

Figure 1: Create the in-situ structure.

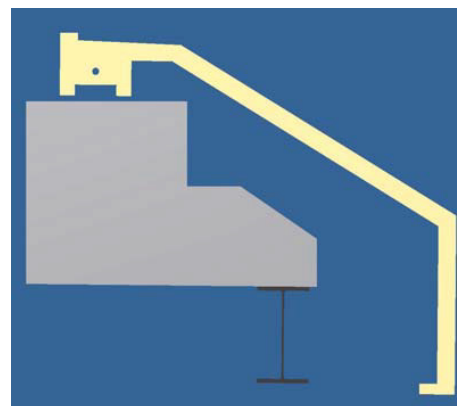

Figure 2: Generate the GRC profile.

"Using 3D has the advantage of making this process fast, efficient, accurate and easier than traditional 2D drafting techniques."

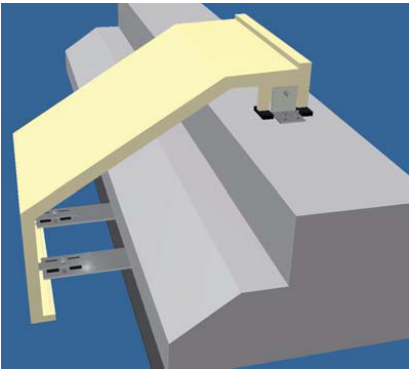

Figure 5: Visualise accessibility for fitting.

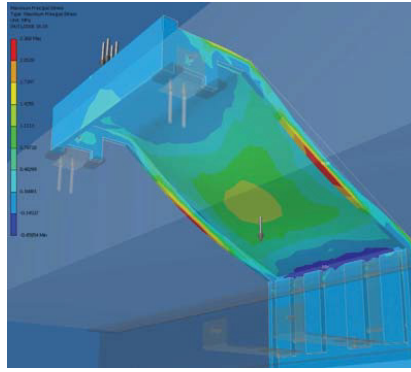
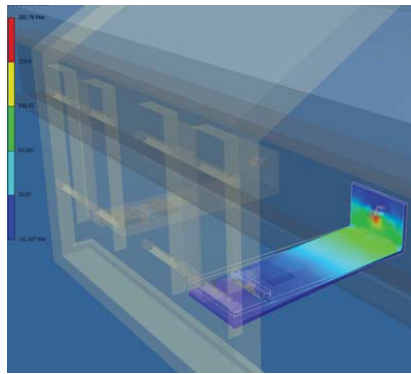
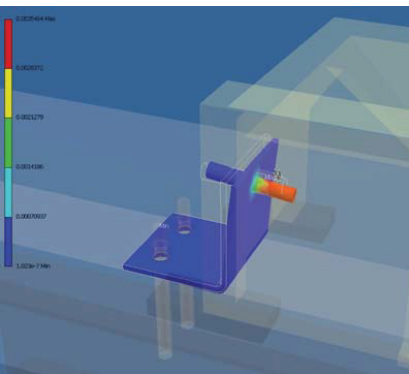

Figure 6: Ensure GRC is designed to an optimum.



Figures 7 and 8: Assess fixings are sufficiently designed.

Now the GRC element has been detailed and the fixing items set out, with the correct installation tolerances taken into account, we can begin to perform a structural analysis upon the element and the fixing brackets. A point to note is that it is also possible to calculate the reactions at the fixing locations. This is especially useful when detailing fixings into concrete near a slab edge, when edge distances must be considered in relation to resin anchor or expansion bolt performance.

Allied to this is the ability to calculate reactions within the GRC element itself, which is very useful when examining local stresses around cast-in brackets, flex anchors or sockets (Figures 6–8).

Once the design/detailing is complete then the process of drawing production can begin (Figure 9).

It is important to note that only one 3D model has been created throughout to provide all the information indicated. We can also interrogate the 3D model to perform clash detection and tolerance

“Perhaps one of the greatest advantages is that the drawing is a ‘live’ document.

If for any reason the 3D model is updated, altered or amended, then the drawing sheets and all the affected information contained within them will also update automatically to suit the most up-to-date version of the working 3D model.”

testing and can examine draft angles and check models for ease of removal from mouldwork or formwork.

If we are required to provide any parts lists or cutting schedules, the drawing will provide this information automatically from the 3D models contained within the drawing. Perhaps one of the greatest advantages is that the drawing is a 'live' document. If for any reason the 3D model is updated, altered or amended, then the drawing sheets and all the affected information contained within them will also update automatically to suit the most up-to-date version of the working 3D model.

Concluding remarks

As we are using a single model to provide all the data required for concept design, working design, structural analysis, drawing production and detail amendments, we can see that the process of drawing production becomes very streamlined and efficient. Therefore, we strongly recommend for anyone involved in the field of GRC design engineering that you give it a try and we are sure that you too can reap the benefits of working in 3D.

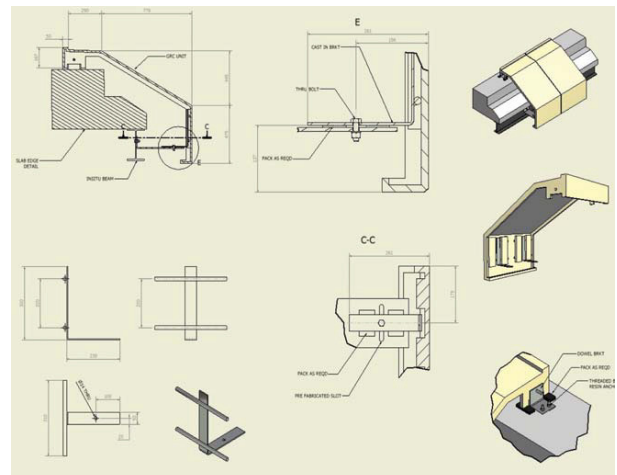

Figure 9: Provide construction/ fabrication drawings.